

# Frigoríscope



News from Transfrigoroute International – Issue 19 – May 2014

## Editorial

Dear reader,

This edition of the Frigoríscope will provide you with an update on key EU political developments affecting our sector this year, an insight into the upcoming Transfrigoroute International AGM, taking place in Brussels in October, and a progress report on TI activities since our last edition in December 2013.

The Brussels bubble is buzzing following the European parliamentary elections on 22 - 25 May. With increasing trepidation many EU and national leaders saw the rise of populist parties and a tangible increase in Eurosceptics' power. Despite the steadily growing momentum of parties such as UKIP in Britain and the Front National in France, however, these groups will still bow to the political majority of Europe's two major parties - the center-right European People's Party and the resurgent Socialists and Democrats.

The other focal point of political debate is the imminent election of the new President of the European Commission. For the first time in history, the political parties which ran in the European Parliament elections are trying to impose their champion as head of the Commission. This means that German socialist Martin Shultz and Luxemburgish center-right Jean-Claude Juncker are on the shortlist. However, we take the bet that the ultimate victor will be an outsider, who will win the position in a last minute deal between the Parliament and the Member States.



S&D and EPP candidates Martin Schultz and Jean-Claude Juncker (*left to right*), who are the two top candidates for President of the next European Commission. But will one of them really get the job?

### In this issue:

#### P.2- Regulatory Update

- Eco-focus across the board: Weights and Dimensions and F-Gas

#### P.3 Internal News

- 2014 AGM
- The Transport of Pharmaceuticals & TI in the new EU

#### P.4 Feature & Calendar of Events and Meetings

Traceability of Temperatures during Transport

Policy-wise, 2014 marks an important year for Transfrigoroute, with many key legislative dossiers making their passage into European and national law. The changing political dynamics in Brussels have fuelled progress in important policy areas as politicians sought to consolidate their legacy before leaving their posts. Indeed important developments such as the revision of the Weights and Dimensions Directive and the rubber-stamping of the F-Gas regulation will fundamentally impact the design, operation, and servicing of temperature-controlled vehicles in the long-term.

Internally, TI is currently in the midst of preparation for our 2014 AGM, which will take place on 16th and 17th October in Brussels. What better way to introduce our sector to the faces of the new EU than by hosting our landmark gathering on their home turf just as they begin their mandate? By demonstrating our sector's well-established presence and network in Brussels, we can hit the ground running to ensure our political priorities are aligned with those at the helm of Europe's future leadership.

With best wishes,

Russell Patten  
Secretary General  
Transfrigoroute International



## European Parliament votes on new Weights and Dimensions Directive

On 15th April the European Parliament voted its position on the proposal to revise the Weights and Dimensions Directive. The proposed rules seek to enhance lorries' safety and reduce their environmental footprint by allowing for the redesign of truck cabins. However, the Parliament decided to delay any action on cross-border circulation of 'mega-trucks' in the EU, instead calling on the Commission to carry out an impact study in this area by 2016.

The Parliament's vote on the new Weights and Dimensions Directive means that incoming MEPs have a base text to work off following the European elections. The proposed revision of the rules is aimed at improving the safety, economic and environmental performance of heavy-duty vehicles. An adaptation to technical progress of the type-approval requirements on their masses and dimensions within the framework of existing Regulation will also accompany the new legislation.



The MAN and Krone ConceptS presented at the IAA 2012 is thought for long distance and could have the aerodynamic resistance of a regular car. © MAN

The changes to the law will directly impact the working methodology and the economic value of equipment for the operating members of TI. The new Directive will allow for the redesign of cabins in order to incorporate built-in alternative fuel engines and other aerodynamic features to enhance sustainable mobility and improve the safety of drivers, pedestrians and cyclists in Europe.

MEPs decided to postpone any work on the cross-border circulation of 'mega-trucks', instead leaving this decision to the Member States. The Parliament will revisit this in the future, but only after the European Commission has presented a thorough impact assessment of the effects of heavy-duty vehicles' movement in Europe by 2016.

There is still much work to be done before the proposed rules are approved. They are being discussed at length by the Member States, who will have to give their all-important seal of approval to the text in the EU Council, due to vote its position on 5 June. If endorsed, the new trucks could become mandatory on European roads from 2022.

## Member States approve revised F-Gas Regulation

On 14th April the EU Council adopted the consolidated text of the new F-Gas Regulation, which will see a phase-down of the use of f-gases in heating and cooling equipment over the next five years.



Rapporteur of the new F-Gas Regulation, MEP Bas Eickhout © European Parliament

The new law will come into force by January 2015 and will impact the stationary and mobile refrigeration sectors, both in terms of compliance obligations and the availability of f-gases for use in vehicles in the future.

Provisions for the transport sector:

- A service ban limited to refrigeration equipment of 40 tonnes of CO<sub>2</sub> equivalent or more

from 1 January 2020 (most trucks fall outside of the scope);

- There are no placing on the market bans for mobile equipment;
- The placing on the market of pre-charged equipment containing HFCs will be allowed after 2017 only if the refrigerants contained in the equipment are part of the quotas through a traceability scheme,
- Products such as extruded polystyrene and other foams using HFCs would be banned from 2020 and 2023 respectively.

Another key consideration for Transfrigoroute will be the methods of implementation pursued by Member State governments. It is likely that they will mainly employ fiscal measures to enforce the rules at national level.

### 2014 AGM theme - The Transport of Pharmaceuticals

On 16th and 17th October 2014, we will host our AGM in Brussels. The meeting will focus on the transport of pharmaceuticals and will allow members to interact with the pharmaceutical industry, to learn about the key rules and laws to follow and to define a harmonised TI position on issues such as the certification of vehicles.



The theme of this year's AGM will be 'The Transport of Pharmaceuticals' in view of the new EU guidelines on the subject published end of 2013. The meeting will provide an open and lively forum for discussion on key areas of interest to our members such as traceability, temperature monitoring, producers and users of products, as well as training programmes and standards in test centres.

High-level representatives from the pharmaceutical industry will be invited to attend and speak at the AGM with a view to building relations and fostering cooperation between our two complementary industries.

The meeting also represents an opportunity for our members to engage with each other and external stakeholders on hot legislative dossiers, such as weights and dimensions, f-gas, cabotage in the domestic transport of goods, and emissions from non-road mobile machinery. Impacting our members in many diverse ways, these areas of legislation are of vital interest to TI and an update on their progress will represent a priority item in our agenda this year.

Preparation is well underway in Brussels and we look forward to providing you with more information in our next edition of Frigoiscope.

### Report on the February 2014 meetings of TI

On 13th February 2014 we held the meetings of the Executive Committee, the Technical Advisory (CCT) Management Committee, the Frigoclub International Board (FCI), and the TI Secretary Generals in Brussels.

A key outcome of the Executive Committee meeting was its decision on the theme of this year's AGM - 'The Transport of Pharmaceuticals'. The Committee agreed that such a topical and politically relevant issue is likely to attract a large audience, as well as offering key profiling and networking opportunities for our members.

In the CCT, Olivier Fontaine and André Stumpf were elected as CCT Vice-Presidents for 2014 and CCT Chair Joe Grealy welcomed Dermott Crombie (Thermoking) as a new member of the Committee.

The CCT and the FCI have together followed the F-gas dossier closely. The new rules do not create an immediate threat for transporters, who will be able to continue to use their equipment. However, servicing them will become more expensive in the coming years as F-Gas becomes less available on the mar-

ket. Both Committees held lengthy discussions about the impact of these changes on our members, and emphasised the need to take them into consideration when purchasing equipment.

The FCI reviewed national hygiene guidelines and will continue to share best practice in upcoming meetings. Board Members also discussed various ways to ensure newly elected decision-makers are aware of our sector and TI members in light of the EU elections.

The Secretary Generals convened to discuss ways to enhance internal cooperation and agreed to have more frequent face-to-face meetings between Members. They also discussed activities at national level to assess the impact of incoming regulatory changes, such as the new F-Gas rules.

## Feature & Calendar of Events & Meetings

### Feature: Traceability of Temperatures during Transport

Valère Lasserre, Secretary General of Transfrigoroute France, has contributed the below feature piece to this quarter's Frigoriscope on the traceability of temperatures during transport.

The texts of the so-called 'Food Package' demand results from all operators of the food chain, whether on the traceability of the goods they handle, on the preservation of the hygiene of these foodstuffs or on the respect of their temperature, which is set either by law or by their producers.

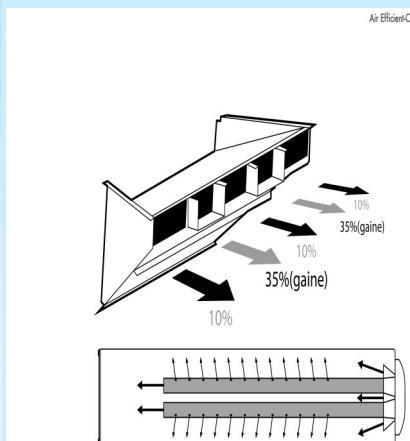

In addition, the instruments use to record the temperature of the air in which frozen foods are stored or transported must conform to certain standards.

However, although standards 12830, 13485 and 13486 clearly define the procedures for the manufacture and periodic verification of temperature recorders, they provide no indication of where measures must be taken, whether in a storage room or in a refrigerated body, to ensure that the air temperature measured is relevant and guarantees optimal storage and transport conditions.

In order to give transporters the insurance of reliable and accurate measurement of temperatures during transport (except during local distribution, which is exempt from the obligation of recording by Regulation 37/2005), **Transfrigoroute France is in the process of defining a framework for a study on this issue which, once validated by French transporters, will be carried out by Cémafroid, the official French testing station.**

TF and TI members will be kept regularly up to date on the development and progress of the study.

### Upcoming Events & Meetings

Event	Organiser	Venue
<b>3 June 2014</b> • CCT working Group 3 "Environmental savings" • CCT Management Committee	TI	Charleroi (Michel Logistics)
<b>4 June 2014</b> • Secretary Generals Meeting • FCI Meeting • Executive Committee Meeting	TI	Charleroi (Michel Logistics)
<b>25 September - 2 October 2014:</b> 65th IAA Commercial Vehicles	IAA	Hannover
<b>30 September - 2 October 2014:</b> 6th Global Logistics Conference	Cool Logistics	Rotterdam
<b>7 - 10 October:</b> Working Party on the Transport of Perishable Foodstuffs (70th session) , Annual Meeting of the UNECE WP.11	UNECE	Geneva
<b>16 - 17 October 2014:</b> TI AGM	TI	Brussels
<b>15-16 October 2015:</b> TI AGM	TI	Amsterdam

Transfrigoroute International is a federation, founded in 1955, whose aim is to promote the development of the transport of temperature-controlled foodstuffs and goods, in solid and in liquid form.



Transfrigoroute International  
46 Avenue des Arts, Brussels 1000  
Belgium

Sponsor

